

**FoodSafe™**



081

Only Piper's equipment has the advantage of **FoodSafe™** technology and certification. This ensures that your food is kept "out of the **DANGER-ZONE.**" Food spoilage occurs mainly because of rapidly accelerated bacteriological activity within the 40F-140F "**DANGER-ZONE.**"

Since there is no simple way of knowing when the degree of contamination has risen to a level which could result in illness or death, chilling or freezing food rapidly is the only **FoodSafe™** answer. FDA & HACCP regulations permit a maximum of 6 hours to chill food from 140 to 40 degrees, while some states now permit only 4 hours. This is 6 to 8 times faster than what traditional refrigeration equipment can accomplish.

Blast chilling and shock freezing are the key factors in HACCP compliance and the fight against foodborne pathogens. **Nothing does it better than FoodSafe™.**

**INTERNAL FITTING:**

- ◆ Stainless steel glide supports joint fixed in the sides of the cooling compartment.
- ◆ Distance between the slides couples is 2.56"

**COOLING UNIT:**

- ◆ Hermetically sealed compressor
- ◆ Evaporator fitted with high flow rate fan for maximum cooling efficiency
- ◆ Fans with indirect flow onto the product eliminates dryout of product
- ◆ Ecological refrigerant R404A
- ◆ Manual defrosting device and evaporation system of water condensation without electrical energy

**VERSIONS / OPTIONAL ACCESSORIES:**

- ◆ Remote cooling unit.
- ◆ Water cooled unit.
- ◆ Caster kit
- ◆ UV sterilization system
- ◆ Printer kit (HAACP)
- ◆ Left hinged door
- ◆ Extra charge for USB connection (Request upon order of blast chiller)

JOB \_\_\_\_\_ ITEM # \_\_\_\_\_ QTY # \_\_\_\_\_

**MODEL NUMBER**

- RCR 081 S/T
- RCM 081 S/T

**ELECTRICAL CONTROL BOARD:**

- ◆ Electronic control board equipped with display, which shows the status of the appliance in every moment.
- ◆ The microprocessor is able to memorize till 100 programs.
- ◆ The "T" electronic control can memorize eventual alarms, and can control up to 4 core probes or 4 sensors Defrosting with activation of an electric heating element fitted on the evaporator.
- ◆ Compressor protected by overload cut-out with automatic reset Microswitch cuts out the evaporator fan and compressor when the door is opened.

**GENERAL FEATURES**

- ◆ Monoblock construction.
- ◆ Outside side-panels and top in stainless steel (Scotch-Brite satin-finish)
- ◆ Insulated stainless steel door with Scotch-Brite satin finish
- ◆ Deflector can be opened on side hinges, in order to clean the evaporator
- ◆ Inside bottom die-formed leakproof
- ◆ Insulation in high-density (93 lbs) expanded polyurethane,
- ◆ 2.36" thick, HCFC-free
- ◆ Copper evaporator coil with aluminum fins protected against corrosion with an electronically applied epoxy paint 20 microns thick
- ◆ Copper condenser with aluminium fins at high thermic efficiency
- ◆ Electro-Fin (coating to protect fins from corrosion)
- ◆ Anti-condensation heating element in the body, below the magnetic gasket
- ◆ Full length ergonomic handle and magnetic gasket on all four sides of the door
- ◆ Stainless steel feet 2" with adjustable height 5.91-7.09"
- ◆ Self-closing doors with stop in open position at 100°
- ◆ Heated core probe standard (in blast freezers) for easy extraction
- ◆ Standard right hinged door

**WARRANTY**

- ◆ One year parts and labor. Warranty is detailed on inside front cover of the price list.

**SPEC S-3**

**PIPER** 300 S. 84th Avenue  
 The Food-Focused Equipment Company Wausau, WI 54401  
 Phone: 800-544-3057  
 Fax: 715-842-3125  
[www.piperonline.net](http://www.piperonline.net)

| Model                               | RCR081           |              | RCM081                                       |            |
|-------------------------------------|------------------|--------------|--|------------|
| Control                             | S / T            |              | S / T  |            |
| Dimensions                          | LxPxH<br>[WxDxA] | mm<br>[in]   | 790x800x1320<br>[31.1x31.5x52]               |            |
| Door opening width                  |                  | mm<br>[in]   | 670<br>[26.4]                                |            |
| Door opening height                 |                  | mm<br>[in]   | 630<br>[24.8]                                |            |
| Internal depth                      |                  | mm<br>[in]   | 460<br>[18.1]                                |            |
| Thickness                           |                  | mm<br>[in]   | 60<br>[2.4]                                  |            |
| Climatic class                      |                  |              | T  |            |
| Chilling capacity                   | 90'              | kg<br>lb     | 25<br>55                                     | 25<br>55   |
| Freezing capacity                   | 240'             | kg<br>lb     | -  | 16<br>35   |
| Hour yield in freezing              |                  | kg/h<br>lb/h | -  | 24<br>53   |
| Refrigerant                         | gas              |              | R404A  |            |
| Refrigeration capacity              | ( ° ) W          |              | 2255   | 1745       |
| Electric power supply               | V/~ /Hz          |              | 208-240/1/60                                 |            |
| Input electric power                | ( ° ) W          |              | 1471   | 1786       |
| Nominal power                       | ( ° ) HP         |              | 2 1/2  | 2 1/2      |
| Max. absorbed current               | ( ° ) A          |              | 8,3  | 10,1       |
| Input el. power without R. Unit     | ( ° ) W          |              | 150  | 170        |
| Max abs. current without R. Unit    | ( ° ) A          |              | 0,9  | 1,1        |
| Setting up Catering                 |                  |              | 8 GN1/1                                      |            |
| Interstep Catering                  | mm<br>[in]       |              | 65<br>[2.6]                                  |            |
| Setting up Baking                   |                  |              | 8 EN   |            |
| Interstep Baking (upright holes)    | mm<br>[in]       |              | 32,5 (17) - 50 (11)<br>[1.3 (17) - 1.9 (11)] |            |
| Setting up ice-cream (shelves)      |                  |              | -  | -          |
| Interstep Ice-cream (upright holes) | mm<br>[in]       |              | -  | -          |
| Net weigh                           | kg<br>lb         |              | 138<br>304                                   | 142<br>313 |
| Noise level                         | dB(A)            |              | < 70   |            |

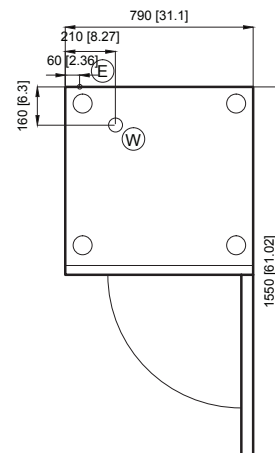
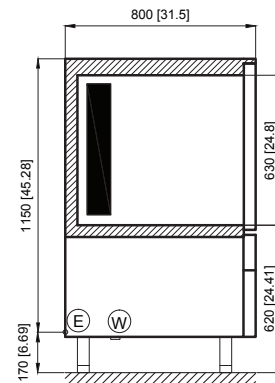
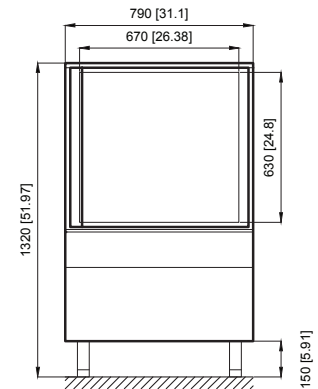

mod. \_\_R\_\_ ( ° ) Temp. evap. -10°C [+14°F] Temp. cond. +45°C [113°F]  
 ( ° ) Temp. evap. 0°C [+32°F] Temp. cond. +55°C [+131°F]  
 mod. \_\_M\_\_ ( ° ) Temp. evap. -25°C [-13°F] Temp. cond. +45°C [113°F]  
 ( ° ) Temp. evap. -10°C [+14°F] Temp. cond. +55°C [+131°F]

(E) ELECTRICAL CONNECTION

(W) DRAIN CONNECTION

DIMENSIONS mm [in]

### S-3 SPEC

**PIPER**  
The Food-Focused Equipment Company  
[www.piperonline.net](http://www.piperonline.net)

300 S. 84th Avenue  
Wausau, WI 54401  
Phone: 800-544-3057  
Fax: 715-842-3125

**LIMITED WARRANTY:** PIPER PRODUCTS warrants to the original purchaser parts and labor for a period of twelve (12) months from the date of purchase. See manufacturer's complete warranty for details.

It is our policy to build equipment which is design certified by companies that have been accredited at the Federal Level by the Occupational Safety and Health Agency (OSHA) and ANSI as a National Recognized Testing Laboratory. These companies include CSA International, Underwriters Laboratories, and the National Sanitation Foundation. However, a continuing program of product improvement makes it necessary to submit new models to the agencies as they are developed. Consequently, all models may not bear the appropriate labels at all times.

We reserve the right to change specifications and product design without notice. Such revisions do not entitle buyer to corresponding changes, improvements, additions or replacements for previously purchased equipment. Information is not for design purposes.